

DACHSHUND

- Thin paper or foil is recommended.
- Start with colored bird base.
- A 10 inch square makes a 5 1/2 inch long model.

Jim Adams

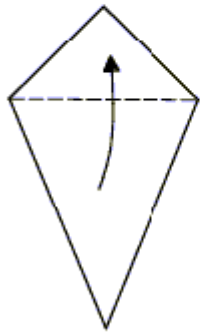

1. Start with a colored bird base. Fold top layer only.

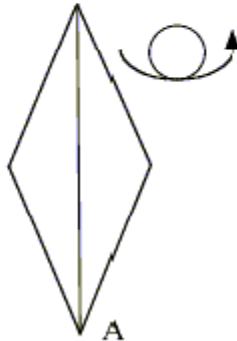

2. "A" marks the end with multiple flaps.

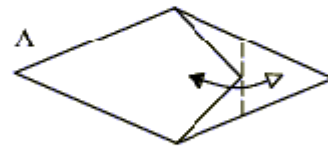

3.

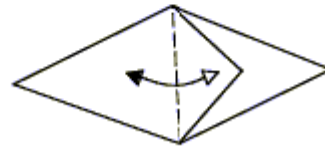

4.

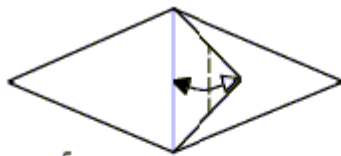

5.

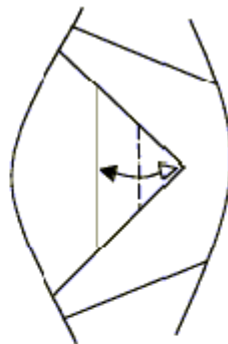

6. This is a close-up view of the center flap.

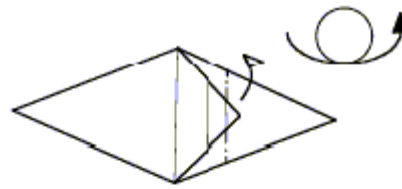

7. Fold bottom flap only.

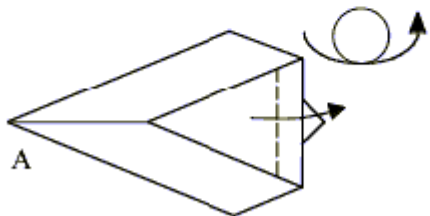

8. Fold is on existing crease.

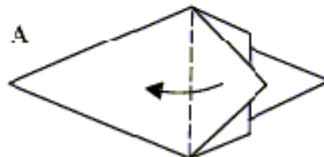

9.

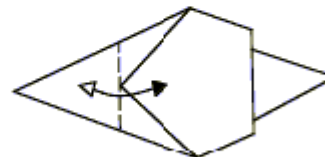

10. Crease all layers.

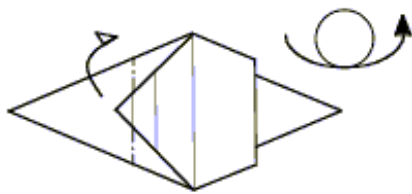

11. Fold bottom flaps only.

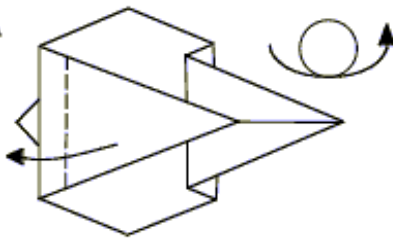

12. Fold all flaps along existing crease.

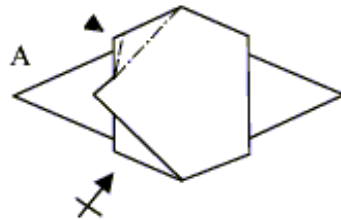

13. Inside reverse fold.

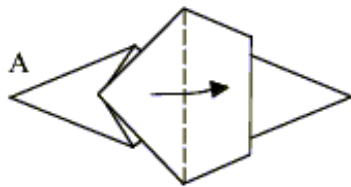

14.

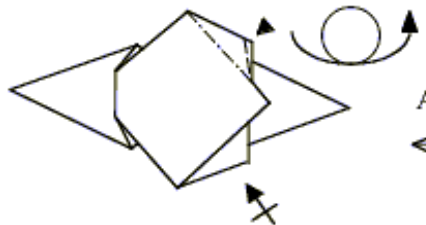

15. Inside reverse fold.

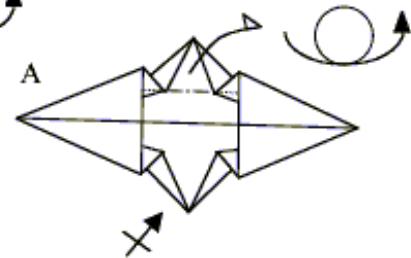

16. Fold point behind.

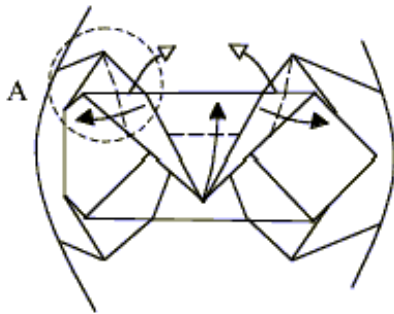

17. Release trapped paper and swivel fold on left and right. See close-up in step 17A.

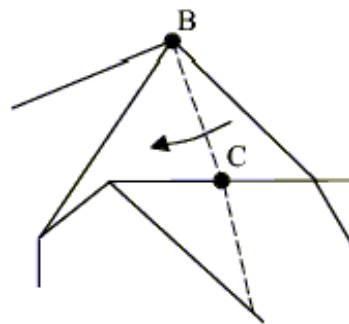

17A. Crease BC aligns with hidden edge on far side.

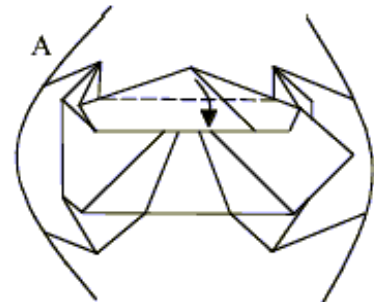

18. Fold aligns with hidden edge.

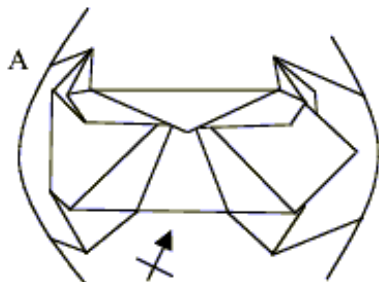

19. Repeat steps 17 - 18 on the bottom flap.

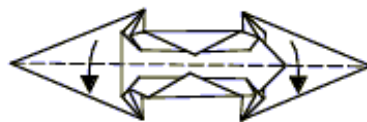

20. Fold in half.

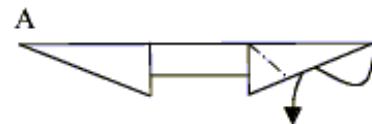

21. Inverse reverse fold. (See step 22.)

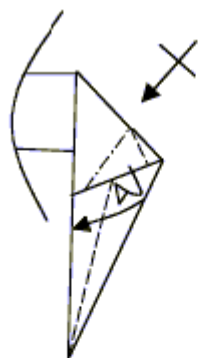

22. Inside reverse fold.

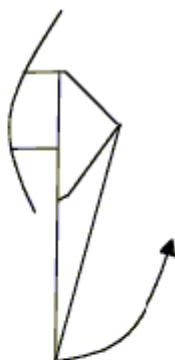

23. Inside reverse fold. See step 24.

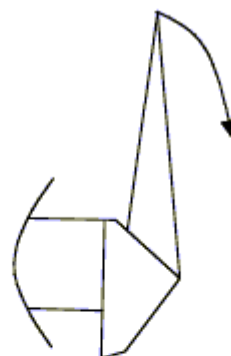

24. Inside reverse fold. See step 25.

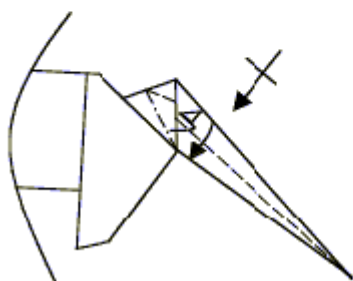

25. Inside reverse fold.

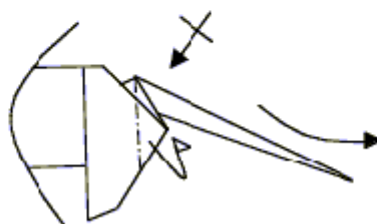

26. Blunt rear with mountain folds and shape tail.

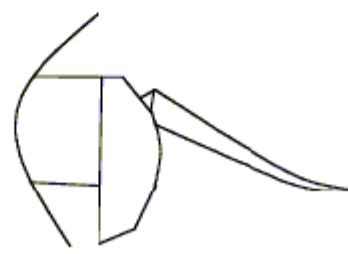

27.

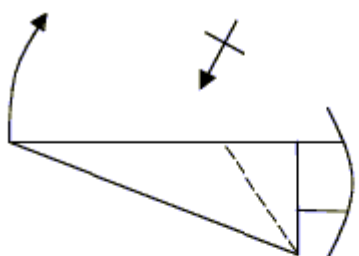

28. Valley fold the outer flaps.

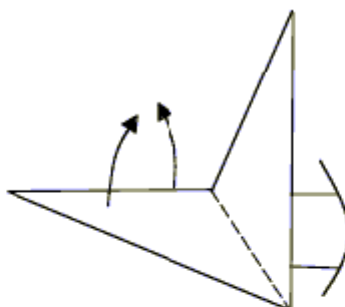

29. Outer reverse fold.

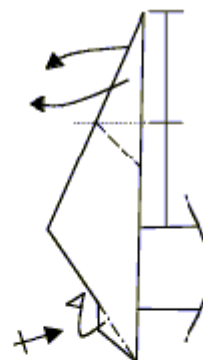

30. Outer reverse fold outer flap only.

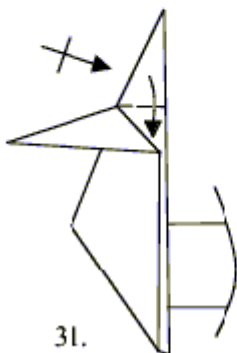

31.

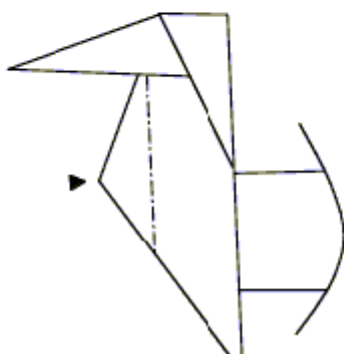

32. Open sink. (Making inside reverse folds on the hidden portions of the ear flaps will help keep all of the layers from separating.)

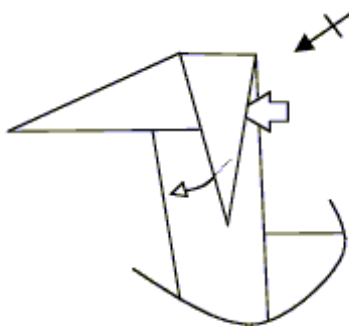

33. Open ear flap from side and squash flat. See steps 33A - 33C.

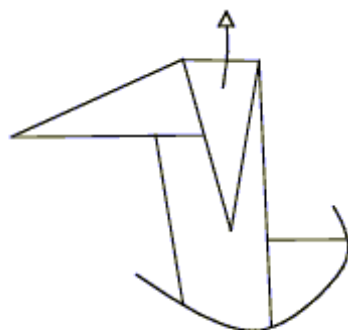

33A.

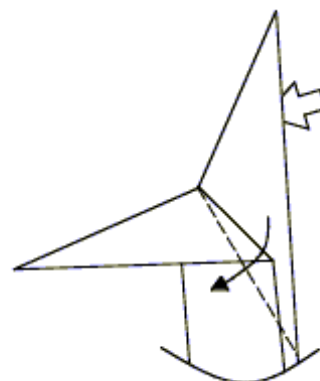

33B. Fold top layers only. Model will not lie flat.

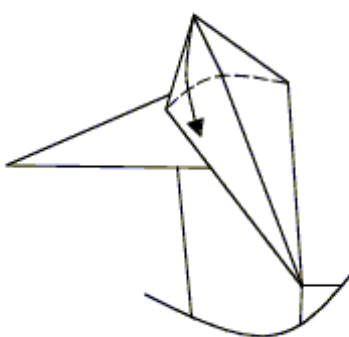

33C. Squash fold to flatten model.

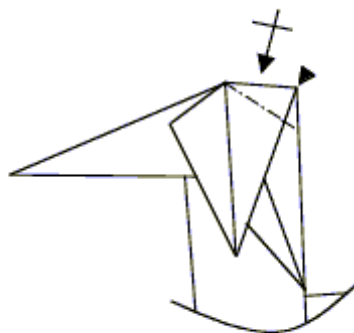

34. Inside reverse fold.

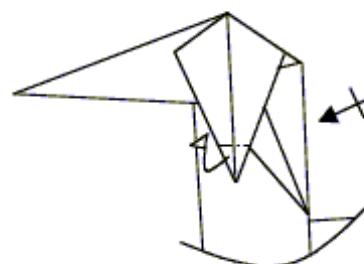

35. Blunt ear flaps with mountain folds.

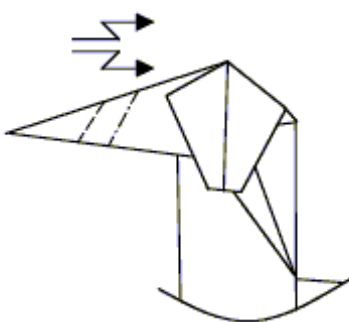

36. Crimp fold muzzle.

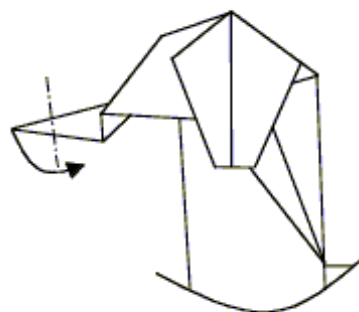

37. Blunt muzzle.

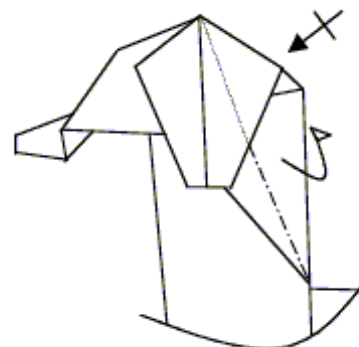

38.

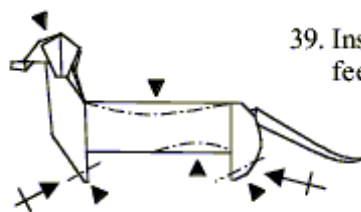

39. Inside reverse fold to form feet. Round and shape body.

